

## Pass-guard System Setup and Connections

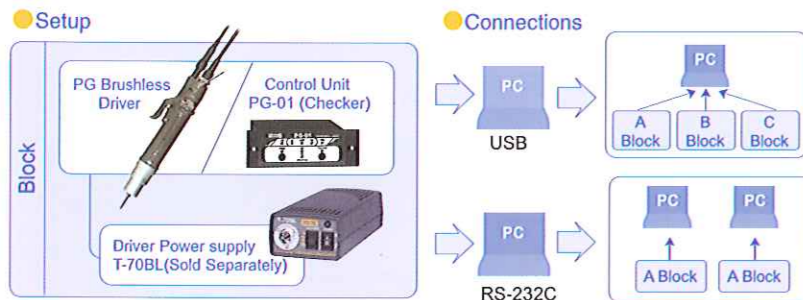

## Driver Power Supply T-70BL (Sold separately)

**Specifications**

Model	T-70BL (Supports 1 driver)
Input voltage	AC100V-240V (47-63 Hz)
Power consumption	70W
Secondary output	2 step HI / LOW
External Dimensions (mm)	88x210x52 (H) mm
Weight (g)	830g
Power cord length (m)	1.8m (Insulated)
Accessories	Mounting brackets (2), Mounting screws (4)

## PG Brushless Drivers

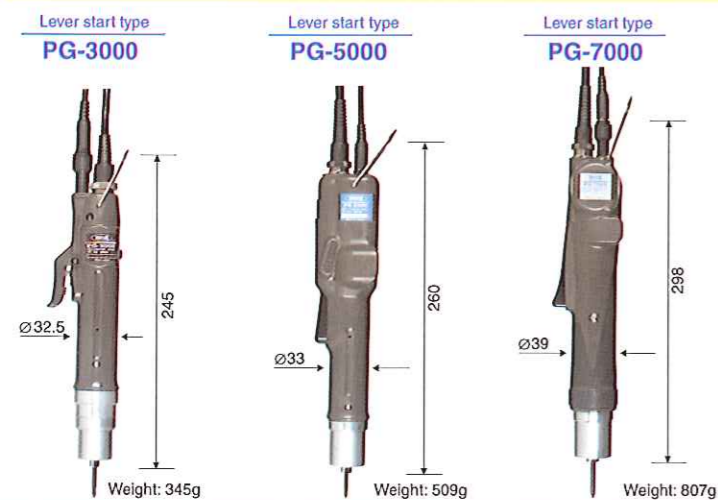

**Specifications** \*PG Drivers are available only lever-start type

Model	PG-3000	PG-5000	PG-7000
Output Torque Range			
N·m	0.2-0.55	0.4-1.2	0.7-2.8
lbf·in	1.7-4.8	3.5-10	6.1-24
(kgf·cm)	(2-5.5)	(4-12)	(7-28)
Torque Switching	Stepless Adjustment		
Unloaded Rotation Speed (r.p.m) ±10%	High	980	900
	Low	680	590
Screw Size (mm)	Small Size Screw	1.7-2.3	2.3-3.0
	Tapping Screw	2.0-2.3	2.0-2.3
Bit Type	Hios H4	Hios H4	Hios H5 or 1/4HEX
Driver cord length / Sensor cord length(m)	2m(6P) / 2m	2m(6P) / 2m	2m(6P) / 2m
Included accessories	Hios bit, Sampling Demo software (Windows XP Excel), RS-232C cable, USB cable, AC adapter (AC100-240V compatible)		

N.B: Windows XP and Excel is Trade mark of Microsoft.

The PG Brushless body uses an antistatic body case to prevent the generation of static electricity, which is suitable for the assembly of precision equipment and electronic parts.

RoHS The PG Brushless is RoHS compliant.

## Control Unit PG-01 (Checker)

### Front Panel (Name and Functions)

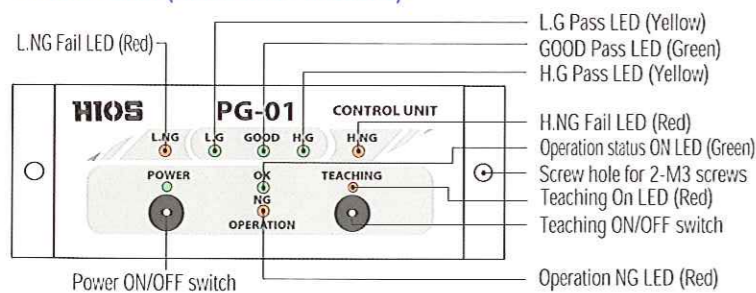

### Rear panel

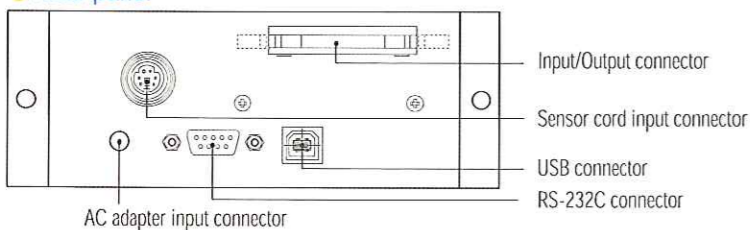

### Specifications

Model	PG-01				
RS-232C Communication	Communication speed	Start Bit	Stop Bit	Data	Data format
	4800BPS	1 Bit	1 Bit	8 Bit	ASCII
External Dimensions (mm)					
	*Dimensions do not include protrusions				
Weight(g)	520g				
AC Adaptor	Input:AC100V-240V (50 / 60 Hz), Output:DC12V				

### I/O input/output connector

Pin No.	Output Signal	Description
13	L.NG (Fail)	Torque is below the LOW GOOD value (L.G)
14	L.G (Pass)	Torque is within the allowed percentage range of the LOW GOOD value
15	GOOD (Pass)	Within the HI and LOW values
16	H.G (Pass)	Torque is within the allowed percentage range of the HI GOOD value
17	H.NG (Fail)	Torque is above the HI GOOD value (H.G)
18	COM GND	-

# HIOS®

Pass/Fail Checking Driver Catalog **09A**

Real-Time OK/Error Detecting Screwdriver

# PG Brushless®

## Brushless Driver Series

### Are those screws properly tightened?

Pass-guard, for tightening all screws

**Tighten** **Check** **Save**



The color of actual drivers may differ from the picture

## Hios Inc.

111-6 Akiyama, Matsudo City, Chiba Pref., Japan  
Phone: +81(Japan) 47-392-2001  
Facsimile: +81(Japan)47-392-7773

Service Center in Shenzhen  
Hios (Shenzhen) Co., LTD  
11CD Room New Times Plaza 1 Taizi Road Shekou Nanshan District Shenzhen Guangdong Province China  
Phone: +86-755-26874278  
Facsimile: +86-755-26858347

<http://www.hios.com/>



ISO 9001 certified Headquarters/Osaka Sales Office/Nagoya Sales Office/Yamagata Factory

**Safety Precautions** Please read the instruction manuals before use. These products should be used only for their intended purposes. The proper and recommended power supply and voltages must be used.

© Specifications or appearance may change/improved without notice. © Reproduction of this catalog without permission is strictly prohibited. © Information in this catalog is current as of April 2009 © Catalogue No. EK-A006

PRINTED WITH SOYINK



# Is that screw really tightened?

You can check in realtime, if each and every screw is tightened properly. Prevents incomplete tightening and provides absolute confirmation and reliable "screw tightening quality."

## Pass-guard

### PG Brushless (DC Type)

All fastening operations are monitored and checked by the criteria, whose value is registered in advance the PG system. The problems in fastening operations such as insufficient torque, wrong thread joint and screw going askew are monitored and prevented from passing through the production line. PG Brushless drivers, which has data collecting function, is a part of "New Fastening System" that meets the demand of latest requirement where zero defect control is required.

The new style of 100% monitoring and control

NEW

### Pass-guard "Tighten," "Check," "Save"

- Instantly determines if a screw passes or fails (OK/NG). (Items checked: torque and time)
- All items can be checked at the same time as the operation is conducted.
- Torque can be monitored for each tightening procedure.
- Can be connected to a PC for data recording.
- Job data can be checked at a glance.



### It's time for environmentally friendly "Brushless driver"

- By using high precision brushless motors, carbon particle emissions are eliminated.
- With a simplified design there is no malfunction nor accident caused by parts.
- A consistently clean environment can be maintained.
- In addition to long life, consistent and stable high precision torque control is promising.
- Minimum heat emissions. (Reduced by approximately 30% according to in-house comparisons)

### Flow of setting Pass Guard System

#### 1. Setting the Pass / Fail values

Screw tightening quality can be controlled by setting the checking criteria.

#### Setting Pass/Fail checking criteria (learned values)

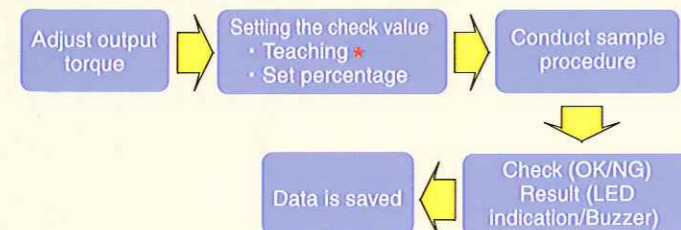

\*The learned values can be changed from the PC default settings screen.

#### Teaching

The checking criteria (learned values) is set by conducting actual screw tightening procedure, the torque value, minimum work time (Main), maximum work time (Max) are then stored.

#### Percentage Setting

Range selection ± (2%, 5%, 10%, 20%)  
The acceptable range of passing values for torque, work time minimum and work time maximum can be set individually.

#### Pass/Fail Value

Fail	Passing range			Fail
L.NG	L.G	GOOD	H.G	H.NG
Below LOW GOOD value	Within the allowed percentage of LOW GOOD value	Within the HI GOOD and LOW GOOD values	Within the allowed percentage of HI GOOD value	Above HI GOOD value
	Min value + (Min % value)	Minimum value (Min)	Maximum value (Max)	Max value + (Max % value)

(Torque value)	L.G	GOOD	H.G
78	2%	80	100
76	5%	80	100
72	10%	80	100
64	20%	80	100

(Work time ms)	L.G	GOOD	H.G
780	2%	800	1000
760	5%	800	1000
720	10%	800	1000
640	20%	800	1000

Example:  
The table above indicates minimum value set at 0.80N·m (Converted to 80), maximum value set at 1.00N·m (Converted to 100) with to minimum work time set to 800ms and maximum work time set to 1000ms.

## 2. All data is saved as work is done

By managing data, it is possible to verify past work details.

### Data display

Measurement data can be displayed in Excel format. Graphs are also generated automatically. You can also develop customized programs to meet the current needs and the current work environment of your application.

### Data sheet (Excel)

### Close-up of data sheet (Displayed items)

	A Actual work values				B Teaching				C Set Percentages				D Check		
	A	B	C	D	E	F	G	H	I	J	K	L		M	N
1	Date	Time	Converted Torque Value (Torque value)	Measurement time (Work time)	Number of times learned (Torque)	Minimum learned value (Torque)	Maximum learned value (Torque)	Minimum learned Measurement time (Work time)	Minimum learned Measurement time (Work time)	Variance	Minimum check value (Torque)	Minimum check value (Torque)	Minimum learned measurement time (Work time)	Minimum learned measurement time (Work time)	*
2	2009/03/01	1:20:19PM	82	850	3	80	100	800	1000	2	78	102	780	1020	E00
3	2009/03/01	1:20:22PM	79	890	3	80	100	800	1000	2	78	102	780	1020	E01
4	2009/03/01	1:20:24PM	103	850	3	80	100	800	1000	2	78	102	780	1020	E94
5	2009/03/01	1:20:27PM	77	850	3	80	100	800	1000	2	78	102	780	1020	E93
6	2009/03/01	1:20:30PM	82	850	3	80	100	800	1000	2	78	102	780	1020	E00

\* Description of check symbols ● E00 (Check=GOOD) ● E01 (Check=LOW OK) ● E02 (Check=HIGH OK) ● E90 (Ended with zero range detected-check not possible) ● E91 (Ended with measurement time error) ● E92 (Ended with incomplete learning-check not possible) ● E93 (Check=LOW NG) ● E94 (Check=HIGH NG) Other

### PC Screen (Excel)

- Click to receive data.
- No of PC com port
- Option only
- "Check" to see in the data sheet "No check" to see in the irregular sheet.
- List of status code
- ①: Gives ±5% of acceptable limit referring to the values of ①. You can choose limit from 2%, 5%, 10%, 15% or 20%.
- ②: Displays the results of fastening referring to the values of ② in yellow.

## 3. Indications during every tightening procedure

OK/NG results can be confirmed by LED and buzzer while work is in process.

OK/NG is displayed on the PC and measurement values are displayed in the data sheet.



\*NG: Not OK

